



**SOUTHERN  
MACHINERY**

**Southern Machinery Sales and Service Co., Ltd.**

# **S1000D Centrifugal Solder Paste Mixer**

## **Operation Maintenance & Repair Manual**

Address: Room 1806, Block 3, Jinyun COFCO, Qianjin 2nd Road, Xixiang, Baoan District,  
Shenzhen City, China      Website: [www.smthelp.com](http://www.smthelp.com)

Tel: +86-755-83203237;

Fax: +86-755-23240492



## Safety Regulations

For safety reasons, please read the operation manual carefully before starting the operation. Parts are subjected to heat, moisture and biological changes, which can lead to functional degradation and even loss of safety resulting in accidents!

Address: Room 1806, Block 3, Jinyun COFCO, Qianjin 2nd Road, Xixiang, Baoan District,  
Shenzhen City, China      Website: [www.smthelp.com](http://www.smthelp.com)

Tel: +86-755-83203237;

Fax: +86-755-23240492

## Foreword

The copyright of this manual belongs to Southern Machinery, and no one may reprint or distribute any content of this manual, including pictures and audio and video materials.

Equipment operators can copy some sections of the manual, but only for internal use, for example, to guide users on how to deal with emergencies. The location of these chapters is clearly indicated in the manual's table of contents.

Southern Machinery shall not be liable for any damage to the machine caused by the user not in accordance with the "machine operating environment" stated in the manual.

Southern Machinery has the right to modify the contents of the operation manual at any time without proper notice.

## Instrument Operating Environment



In order to ensure the safety of continuous use of the machine, the following factors may damage the centrifugal mixer:

- Chemical effects;
- Environmental effects, including natural ultraviolet radiation;
- Corrosion and wear of shield parts and other safety parts.

- \* Indoor use
- \* Altitude:  $\leq 2000\text{m}$ ;
- \* The ambient temperature range of the machine is  $+5^{\circ}\text{C}\sim+40^{\circ}\text{C}$ ;
- \* The relative humidity range of the machine is  $\leq 80\%$ ;
- \* Machine power supply applicable range AC230V 50HZ/60HZ 10A;
- \* The room must be equipped with adequate ventilation;
- \* There is no vibration and airflow around affecting performance;
- \* There is no conductive dust, explosive gas and corrosive gas in the surrounding air;

## Safety Tips

- \* Please read this manual carefully when using this machine for the first time!
- \* S1000D desktop automatic centrifugal mixer can only be operated by trained and authorized personnel;
- \* Maintenance of the equipment can only be done by Southern Machinery or Southern Machinery's authorized agents; \* Strictly prohibit the use of the following materials in centrifugal mixers:
  - Flammable and explosive materials;
  - reinforced chemical materials;
  - Toxic or radioactive substances, or pathogenic microorganisms, etc.
- \* Only qualified maintenance personnel using the appropriate tools can perform service operations on the system of the S1000D desktop automatic centrifugal mixer
- \* If the operator encounters a situation not mentioned in this manual, please contact Southern Machinery or Southern Machinery's authorized agent to ask the correct treatment method.
- \* Try to use the accessories provided by Southern Machinery, if the user wants to use other accessories, Southern Machinery will  
Will not be responsible for the adverse consequences. However, users can apply to Southern Machinery to verify whether the accessories meet the requirements of Southern Machinery.
- \* The S1000D bench automatic centrifugal mixer must be inspected and maintained at specified intervals.

## Description of Safety Warning Signs



**Caution: Instrument in use. Please read the instruction manual carefully before the machine!**



**Caution: High pressure is dangerous! Electric shock hazard!**



## **The meaning of the security statement**

To avoid injury to people around you or damage to objects and the environment, please follow all safety instructions in this user manual.

In addition to the recognized professional rules on accident prevention, environmental protection and safety and occupation, including the laws and regulations of the country where the user is located and the local laws and regulations of the installation of the centrifugal mixer must be carefully observed.

## **The consequences of ignoring safe operating procedures**

Any disregard for safe operating procedures, laws and regulations can result in hazards to people, objects and the environment.

# Catalogue

S1000D Centrifugal Solder Paste Mixer.....	1
Safety Regulations.....	2
Instrument Operating Environment.....	3
Indoor use.....	3
Safety Tips .....	4
The meaning of the security statement .....	5
1 Terms of safe use.....	7
1.1 Operation precautions .....	9
1.2 Relevant reference standards .....	9
2 S1000D table automatic centrifugal mixer introduction.....	11
2.1 S1000D Table automatic centrifugal mixer appearance introduction ...	11
2.2 Overview .....	13
2.3 Brief introduction of equipment structure.....	13
2.4 Safety protection mechanism .....	15
2.5 Machine setting requirement.....	16
3. optional accessories.....	16
4. Preparation before use .....	18
4.1 Transportation and installation.....	18
4.2 Choose a reasonable placement place.....	18
4.3 Fixed placement machine .....	19
4.4 Connect the power supply correctly .....	19
5. Operation instruction .....	19
5.1 Control panel and display interface.....	20
5.2 Power on.....	33
5.3 Open the door .....	33
5.4 Close the door.....	33
5.5 Install the carriage mechanism assembly .....	34
5.6 The calculation of the load of the rotating frame.....	37
5.7 Filling of samples in centrifugal mixing vessels .....	37
5.8 Safe use of rotating frame mechanism .....	38
5.9 Example for parameter setting operations.....	39
6 Maintenance items.....	41
6.1 Cleaning and purification.....	41
6.2 The maintenance responsible by Southern Machinery .....	45
6.3 Warranty (repair) basis .....	46
7 Fault handling.....	47
7.1 Emergency door cover .....	47
7.2 Fault alarm information .....	47
7.3 Machine running record.....	56
8 Technical data .....	58
9 Packing list.....	60
Packing list .....	60

Address: Room 1806, Block 3, Jinyun COFCO, Qianjin 2nd Road, Xixiang, Baoan District,  
Shenzhen City, China      Website: [www.smothelp.com](http://www.smothelp.com)

Tel: +86-755-83203237;

Fax: +86-755-23240492

## 1 Terms of safe use

S1000D Benchtop automatic centrifugal mixers are based on current technical and safety standards:

GB4793.1-2007 "Safety requirements for electrical equipment for measurement and control laboratories Part I: General safety requirements";

GB4793.7-2001 "Safety requirements for electrical equipment for measuring and controlling laboratories - Special requirements for centrifuges for laboratories";

GB191-2000 "Packaging storage and transportation icon";

GB6587.6-86 "Transportation Test of Electronic Measuring Instruments"; Enterprise standard: "Low speed centrifugal Mixer";

Design, so it must be used in accordance with the requirements of the design, if there are the following incorrect or inappropriate use of the method, in the use of S1000D desktop automatic centrifugal mixer, it will cause equipment damage or personal injury:

- Not used according to design requirements;
- Operators and maintenance personnel are not trained;
- Users make inappropriate changes to the design content without authorization;
- Failure to pay attention to or understand safe usage rules.



**Anyone involved in the use or maintenance of the S1000D bench type automatic centrifugal mixer must read and understand the instructions in this manual and safe use rules.**

In addition, in order to prevent accidents, the following rules must be strictly enforced:

This manual is one of the components of the "S1000D Bench Automatic Centrifugal Mixer" device and must be placed with the S1000D bench automatic centrifugal mixer for the operator to consult.

Address: Room 1806, Block 3, Jinyun COFCO, Qianjin 2nd Road, Xixiang, Baoan District, Shenzhen City, China Website: [www.smthelp.com](http://www.smthelp.com)

Tel: +86-755-83203237;

Fax: +86-755-23240492

S1000D desktop automatic centrifugal mixer is designed for solder paste, silver paste, chemical, resin, sealant, adhesive, lubricating oil, mineral and other materials. Suitable for centrifugal stirring and defoaming of semi-fluid and powder.

During the operation of the S1000D table automatic centrifugal mixer (when mixing samples or rotating rack), within a range of 30CM around the centrifugal mixer, it is ensured that there are no operators or harmful and dangerous substances, and there are no items blocking the vent of the centrifugal mixer.

If the following safety measures are not followed when using the S1000D table type automatic centrifugal mixer, the mixer will cause injury to the operator or other persons or damage the mixer unit and the separated samples inside:

- The design of the centrifugal mixer is neither anti-corrosion nor explosion-proof, so the centrifugal mixer can not be used in a corrosive environment and an explosion environment;
- It is strictly prohibited to use the following materials in the centrifugal mixer:
  - Flammable and explosive materials;
  - reinforced chemical materials;
  - Toxic or radioactive materials, etc.
- Used to stir corrosive substances will cause damage to the material inside the centrifugal mixer and destroy or weaken the mechanical strength of the rotating frame, so when stirring corrosive substances, corrosive substances must be placed in the protective container.

Address: Room 1806, Block 3, Jinyun COFCO, Qianjin 2nd Road, Xixiang, Baoan District,  
Shenzhen City, China Website: [www.smthelp.com](http://www.smthelp.com)

Tel: +86-755-83203237;

Fax: +86-755-23240492



## 1.1 Operation precautions

- Before running the centrifugal mixer (when mixing samples), it must be confirmed that the cup body matching the cup specifications is installed, and ensure that it is firmly installed;
- Do not manually open the door and move the centrifugal mixer during operation (when the rotating frame is rotating) or when the centrifugal mixer is stopped (but when the rotating frame is still rotating);
- The parts used in the S1000D desktop automatic centrifugal mixer must be provided by Southern Machinery

For some general parts, such as metal and plastic containers for separation, products that have been confirmed to meet the requirements should also be used, and the maximum speed and maximum centrifugal force of the corresponding tank should be met respectively.

- Never use a centrifugal mixer or stir samples with the door open;
- When the centrifugal mixer is disassembled, please do not turn on the power switch of the equipment (the power cord should be removed);
- The replacement of mechanical parts and electronic devices of the centrifugal mixer must be carried out by the relevant personnel designated by Southern Machinery;
- When the operator uses the centrifugal mixer, the tank with appropriate load must be selected, and the overload must not be used;
- Often check the rotating frame mechanism if the rotating frame structure is found to have obvious corrosion marks or obvious damage, must stop using;
- After use for a period of time, maintenance should be carried out in strict accordance with the provisions of "cleaning and maintenance".

## 1.2 Relevant reference standards

- GB4793.1-2007 "Safety requirements for electrical equipment for measurement and control laboratories Part I: General safety requirements";
- GB4793.7-2001 "Safety requirements for electrical equipment for measurement and control laboratories - Special requirements for laboratory centrifuges";

Address: Room 1806, Block 3, Jinyun COFCO, Qianjin 2nd Road, Xixiang, Baoan District, Shenzhen City, China Website: [www.smthelp.com](http://www.smthelp.com)

Tel: +86-755-83203237;

Fax: +86-755-23240492

- GB191-2000 "Packaging storage and Transportation icon";
- GB6587.6-86 "Transportation Test of Electronic Measuring Instruments";
- Enterprise standard: "Low speed centrifugal mixer";

Address: Room 1806, Block 3, Jinyun COFCO, Qianjin 2nd Road, Xixiang, Baoan District,  
Shenzhen City, China      Website: [www.smthelp.com](http://www.smthelp.com)

Tel: +86-755-83203237;

Fax: +86-755-23240492

## 2 S1000D table automatic centrifugal mixer introduction

### 2.1 S1000D Table automatic centrifugal mixer appearance introduction

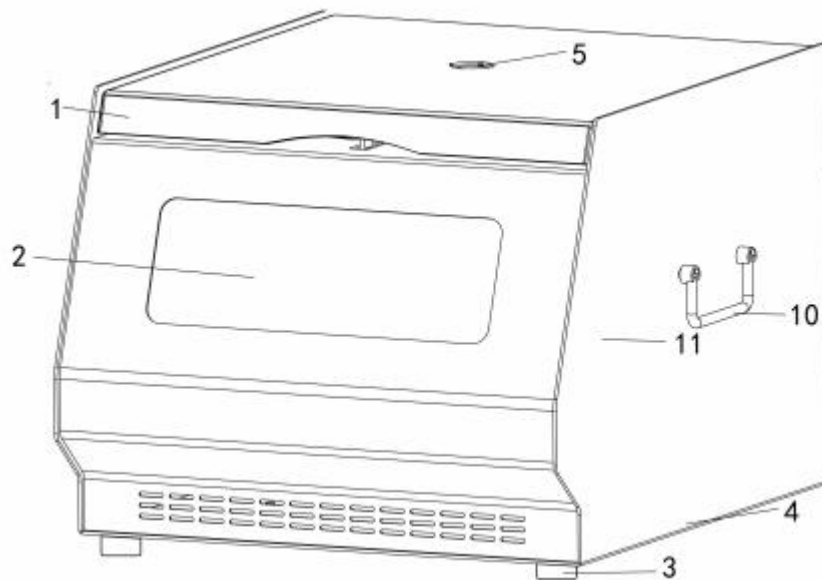

**Figure 1: Front side appearance of desktop automatic centrifugal mixer**

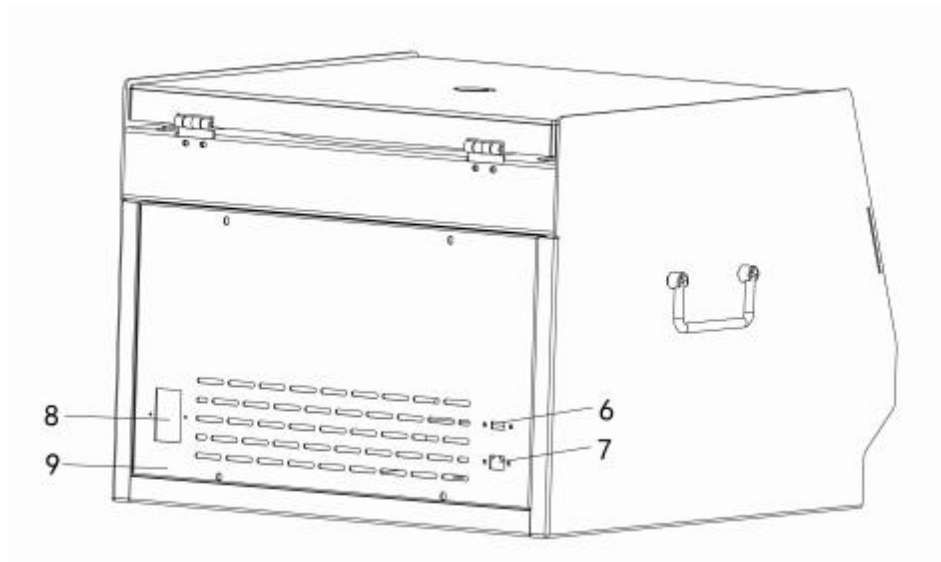

**Figure 2: Table automatic centrifugal mixer rear side appearance**

Address: Room 1806, Block 3, Jinyun COFCO, Qianjin 2nd Road, Xixiang, Baoan District, Shenzhen City, China Website: [www.smthelp.com](http://www.smthelp.com)

Tel: +86-755-83203237;

Fax: +86-755-23240492

**Figure 1 and Figure 2 illustrate:**

1. Door cover
2. Control panel and display window
3. Foot pad
4. Case
5. Viewing window
6. USB interface
7. LAN network port - Reserved
8. Power socket and power switch
9. Heat dissipation hole
10. Handle
11. Pull rope for emergency door opening

Address: Room 1806, Block 3, Jinyun COFCO, Qianjin 2nd Road, Xixiang, Baoan District,  
Shenzhen City, China      Website: [www.smthelp.com](http://www.smthelp.com)

Tel: +86-755-83203237;

Fax: +86-755-23240492

## 2.2 Overview

S1000D desktop automatic centrifugal mixer is a low speed desktop automatic heating and return temperature centrifugal mixer, chemical laboratory, mineral, chemical materials research and industrial laboratory routine experimental analysis and semiconductor and electronic automatic production; It can be widely used in electronic production of silver paste solder paste materials, battery materials, chemical materials, ink and resin glue, mineral and lubricating oil, cosmetic materials, and is a conventional machine used in laboratory and production for centrifugal mixing and centrifugal defoaming. This machine is equipped with a cup (see "Table 1: Type and Technical parameters").

## 2.3 Brief introduction of equipment structure

The equipment is composed of door cover system, cavity system, drive system, temperature control heating, rotating frame system, base shock absorption system, power supply system, control system, display system and alarm system. (Vacuum assembly optional)

**2.3.1** The door cover system includes door cover, door hinge and damper gas spring, door lock, door alarm, emergency door lock rope, etc. The door hinge is inside the back of the frame, and the door lock is in front of the frame. Only when the door lock is locked, the centrifugal mixer can be started to run, otherwise the door alarm system works (buzzer sounds), and the machine cannot be started.

To open the door cover, just click the door key on the touch control panel of the machine. When the door cover is opened to a certain height, the door hinge and damping gas spring can support the door cover.

If there is a power failure or failure of the door opening key, and the sample must be taken out in time, use the emergency door lock rope, and slowly pull out to the right horizontally to manually open the door cover (Figure 1-11).



Room 1806, Block 3, Jinyun COFCO, Qianjin 2nd Road, Xixiang, Baoan District,  
Shenzhen City, China Website: [www.smthelp.com](http://www.smthelp.com)

Tel: +86-755-83203237;

Fax: +86-755-23240492

**When the rotating frame mechanism is rotating and the power is turned on, it is strictly forbidden to use the emergency door lock rope to manually open the door cover!**

**2.3.2** The cavity system includes stainless steel inner liner and rubber sealing ring. The cavity system can provide a stable working environment.

**2.3.3** The equipment adopts brushless DC motor to directly drive the rotating frame of the load cup body to rotate together. The drive system adopts direct drive mode, which makes the rotor and shaft cooperate with high precision and run smoothly.

**2.3.4** The rotating rack system is composed of various application cups (see "Table 1: Rotating rack types and technical parameters") and centrifugal stirring cups and other related accessories. The function of the rotating frame is to load the sample at a certain speed in proportion to the rotation and rotation at the same time, resulting in a relative centrifugal force field, so as to achieve the purpose of defoaming and stirring the sample in the cup. Since the centrifugal force achieved by the rotating frame at low speed is thousands of times more than the Earth's gravitational acceleration  $g$  value, it is very important for the safe use and careful maintenance of the rotating frame!

**2.3.5** The frame system is composed of frame, bottom plate, fuselage shell and rubber support feet.

**2.3.6** The power supply system includes power sockets and switches, which are responsible for the mains power supply required for the normal operation of the machine.

**2.3.7** The control system includes the setting of speed and centrifugal force, the setting of running time, the selection of lifting rate, the control of the whole machine display system and the alarm system. In order to ensure the normal operation of the machine and the personal safety of the operator, do not disassemble the machine at will!

**2.3.8** The display control system is composed of industrial HD touch color screen and full screen virtual touch operation interface (control panel). It is the medium of human-machine dialogue. It can display the parameters set synchronously, and can track the actual changes of the parameters, in addition, it can also display and alarm a variety of faults.

Address: Room 1806, Block 3, Jinyun COFCO, Qianjin 2nd Road, Xixiang, Baoan District, Shenzhen City, China Website: [www.smthelp.com](http://www.smthelp.com)

Tel: +86-755-83203237;

Fax: +86-755-23240492

**2.3.9** The alarm system is equipped with door cover fault, overspeed, imbalance, overvoltage and other alarms. When the machine overspeed, door cover open, imbalance and other fault situations, the system can alarm, at this time, the buzzer alarm sound, the machine can not start (not allowed to start), the running machine will automatically stop, until the fault is removed, the machine can be restarted. Note: To cancel the alarm sound from the buzzer, press the Stop button on the control panel.

## **2.4 Safety protection mechanism**

The S1000D desktop automatic centrifugal mixer has a series of safety protection mechanisms:

- The frame and protective steel ring are made of steel plate, and the internal cavity is made of stainless steel.
- The door cover adopts explosion-proof structure, and the front of the door cover has a locking mechanism. Only when the centrifugal mixer is energized and the rotating frame is stopped, you can press the door key on the control panel to open the door cover of the centrifugal mixer, and only when the door cover of the centrifugal mixer is locked, you can start the centrifugal mixer to work!
- Speeding

When the rotating speed of the centrifugal mixer exceeds the set speed of 400r/min, the machine will make an alarm sound, when the operating speed exceeds the maximum rated speed of the rotating frame 450r/min, the rotating frame will automatically stop running, until the rotating frame is completely stopped, the door can be opened, after troubleshooting, restart operation;

- Imbalance

If the rotating frame is unbalanced during operation, causing the rotating shaft to shake beyond the specified amplitude, the machine will stop running in time and issue an alarm; Generally, the load of the rotating frame mechanism is unbalanced. After the end of operation, open the door cover, after troubleshooting, you can start running again.

- Open doors in case of emergency

Address: Room 1806, Block 3, Jinyun COFCO, Qianjin 2nd Road, Xixiang, Baoan District, Shenzhen City, China      Website: [www.smthelp.com](http://www.smthelp.com)

Tel: +86-755-83203237;

Fax: +86-755-23240492

During the operation of the rotating frame mechanism, if a sudden power failure occurs or the machine fails, the door cannot be opened by pressing the button, the door can be opened manually (see "Troubleshooting").

## 2.5 Machine setting requirement

**2.5.1** The machine should be placed on a horizontal table with sufficient rigidity, and away from the vibration impact equipment, to avoid direct exposure to heat sources and sunlight.

**2.5.2** The four sides of the machine should have 10cm ~ 15cm distance space, so that the machine ventilation and heat dissipation

**2.5.3** After placing the device, adjust the level and ensure that the four supporting feet at the bottom of the device are evenly supported on the platform.

**2.5.4** Machine power supply application range AC230V 50HZ/60HZ 10A.



The machine must be strictly and reliably grounded, and the machine power grounding wire must be reliably connected with the electrical network grounding wire! The rotating frame mechanism is strictly prohibited during operation Power off, otherwise it may cause damage to the control circuit!

## 3. optional accessories

Southern Machinery provides S1000D desktop automatic centrifugal mixer matching specifications of the cup for users to use, you can

In order to buy a desktop automatic centrifugal mixer at the same time, according to your actual use requirements to buy (see "Table 1: cup type and technical parameters").

If you need to purchase optional auxiliary parts in this regard, please consult with the manufacturer or our authorized agent about the technical specifications and purchase numbers of the optional auxiliary parts.

Address: Room 1806, Block 3, Jinyun COFCO, Qianjin 2nd Road, Xixiang, Baoan District, Shenzhen City, China Website: [www.smthelp.com](http://www.smthelp.com)

Tel: +86-755-83203237;

Fax: +86-755-23240492



**Table 1: Cup type and technical parameters**

Rack number (Rotor)	capacity (ml×Number of bottles)	Maximum speed (r/min)	Maximum relative centrifugal force(× g)	Container bottle type
#3202 Rack number	150×2	<b>1000</b>	<b>135</b>	PP flat bottom with cover
	customizable			

Address: Room 1806, Block 3, Jinyun COFCO, Qianjin 2nd Road, Xixiang, Baoan District, Shenzhen City, China      Website: [www.smthelp.com](http://www.smthelp.com)

Tel: +86-755-83203237;

Fax: +86-755-23240492

## 4. Preparation before use

### 4.1 Transportation and installation

S1000D desktop automatic centrifugal mixer is transported in a packing box, which is equipped with buffer protection materials inside. After opening the packing box, the buffer protection materials inside are removed.



**The net weight of the machine is about 68.00Kg. When handling, lift the equipment from the left and right sides of the machine and balance the force! Please carry vertically, do not shake the machine!**

When transporting or moving long distances, use special packing cases, properly fixed and maintained vertically, and should be handled with care.

### 4.2 Choose a reasonable placement place

S1000D desktop automatic centrifugal mixer can only be used indoors, and the location should meet the following requirements:

- When the mixer is running, a safe distance of 20cm must be kept around, and harmful and dangerous substances shall not be placed within this safe distance, and relevant personnel shall not stay;
- The stand or table where the mixer is placed should be firm and not shake and vibrate; If a movable bracket or trolley is used, one with a locking device should be used. To ensure the safe operation of the mixer;
- If the mixer is placed on the wall or corner, in order to ensure smooth air circulation and good heat dissipation, please ensure that the back and left and right sides of the mixer are not less than 10cm and 15cm away from the wall.
- The mixer should be placed away from the window to avoid direct exposure to heat and sunlight.

Address: Room 1806, Block 3, Jinyun COFCO, Qianjin 2nd Road, Xixiang, Baoan District, Shenzhen City, China Website: [www.smthelp.com](http://www.smthelp.com)

Tel: +86-755-83203237;

Fax: +86-755-23240492

- After the mixer is placed, the four supporting feet should be evenly supported on the table, and the level should be adjusted.
- The room where the mixer is placed must be a constant temperature room with the ambient temperature between +5 ° C and 40 ° C and the ambient humidity  $\leq 80\%$ , and keep the environment clean.

### **4.3 Fixed placement machine**

Once the mixer is placed, do not move it at will, if it moves, it should be reconfirmed or the level should be adjusted, and the four supporting feet at the bottom of the machine are evenly supported on the table. Make sure that the support or countertop on which the machine is placed is solid and cannot shake or vibrate.

### **4.4 Connect the power supply correctly**

The power cord of the mixer should use a separate power socket, which must be well grounded, confirm that the power cord used for mixing meets the safety specifications of the country and region where it is located, and the power voltage and power frequency applicable to the mixer should meet the requirements specified in this specification or the specifications marked on the nameplate of the mixer. Please use the power cord that comes with it, connect it to the power socket correctly, and connect it securely to the network power supply. " | " is used when the power switch is closed, and "O" is used when the power switch is disconnected.

## **5. Operation instruction**

Address: Room 1806, Block 3, Jinyun COFCO, Qianjin 2nd Road, Xixiang, Baoan District,  
Shenzhen City, China Website: [www.smthelp.com](http://www.smthelp.com)

Tel: +86-755-83203237;

Fax: +86-755-23240492

## 5.1 Control panel and display interface

1. Conventional centrifugal stirring parameter setting interface After power-on, touch the color screen to display the interface of conventional centrifugal stirring parameter setting, as shown in the following figure:



Figure 4-1: Setting interface of conventional centrifugal stirring parameters

- 1) Door cover status: When the current door cover is OPEN, the Open icon is displayed. When the current door cover is closed, the CLOSE icon is displayed;
- 2) Speed setting: Press the speed or centrifugal force to switch the display setting centrifugal force, the blue bottom is the current speed display;
- 3) Prefabrication heat setting: set the temperature (22.0°C in FIG. 1), display the actual temperature (22.8°C in FIG. 1) and open the prefabrication heat function button:  
-- Press prefabrication heat, and a confirmation start pop-up window appears at the top of the current page, as shown in Figure 2-1;

Address: Room 1806, Block 3, Jinyun COFCO, Qianjin 2nd Road, Xixiang, Baoan District, Shenzhen City, China Website: [www.smthelp.com](http://www.smthelp.com)

Tel: +86-755-83203237;

Fax: +86-755-23240492

-- Click Start to switch to run pop-up window, showing the current prefabricated thermal status, as shown in Figure 2-2:

-- When the prefabrication heat is not completed, click stop, and when the speed drops to 0, the popup disappears; After prefabrication is completed, the system will display a pop-up window as shown in Figure 2-3. Click Exit and the pop-up window will disappear.



Address: Room 1806, Block 3, Jinyun COFCO, Qianjin 2nd Road, Xixiang, Baoan District, Shenzhen City, China Website: [www.smthelp.com](http://www.smthelp.com)

Tel: +86-755-83203237;

Fax: +86-755-23240492



Figure 4-2. General centrifugal fault alarm example interface

## 2.Setting interface

1) Introduction to the setting interface:



Figure 3-1. System Settings screen

Click the setting icon button to enter the setting interface as shown in Figure 3-1 below:

Among them, it should be noted that:

- Drag small slider for brightness adjustment;
- Key sound: Closed can be displayed on the left side of the door cover status in the general centrifugal parameter setting interface: (silent), otherwise it will not be displayed;
- Timing mode: It is the calculation method of motor running time, which is divided into startup timing: the running time of the motor is calculated when the motor starts to rotate

Address: Room 1806, Block 3, Jinyun COFCO, Qianjin 2nd Road,Xixiang, Baoan District,  
Shenzhen City, China Website: [www.smthelp.com](http://www.smthelp.com)

Tel: +86-755-83203237;

Fax:+86-755-23240492

To speed timing: the motor starts to calculate the running time after reaching the set speed.  
Click the four buttons at the bottom of Figure 3-1 to enter the corresponding setting page:

2) Preheating Settings:

Prefabricated heat function can be set under the conventional centrifugal parameter setting interface: motor running speed, preheating target temperature, preheating time and other parameters.

3) System time Settings:

You can change the current system time: year, month, day, hour, second, and press OK to save the current parameter

Count and automatically exit the time setting interface, otherwise, directly press the exit icon in the upper right corner, and exit directly without saving;

4) Running record:

Statistics of all running conditions from the factory,



Figure 3-2

Figure 3-2. The running record page is displayed

Among them, the detailed view is as follows:

Curve record: click < Curve Record > to view the speed, temperature, speed up and speed down curves of the last operation. The blue button on the right is the curve displayed in the current chart.

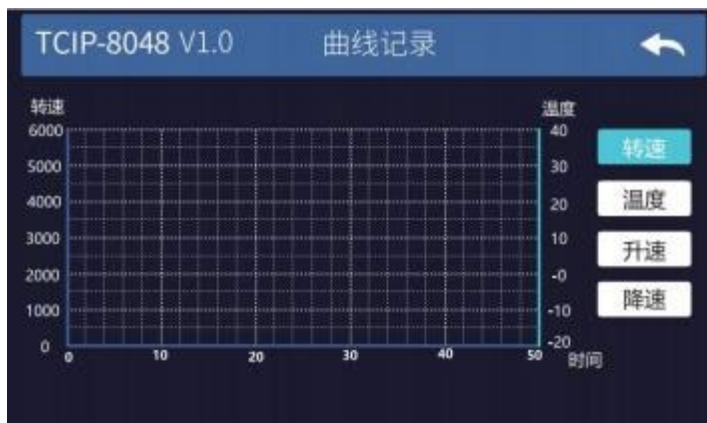

Figure 3-3

b History:

Address: Room 1806, Block 3, Jinyun COFCO, Qianjin 2nd Road, Xixiang, Baoan District, Shenzhen City, China Website: [www.smothelp.com](http://www.smothelp.com)

Tel: +86-755-83203237;

Fax: +86-755-23240492



- To enter the page: Click < History >, you can turn the page through "Previous" and "Next" to view the current historical records. A maximum of 2000 records can be stored, as shown in Figure 3-4.

日期	程序	转子	转速	温度	进程	运行时间	状态

导出 打印 退出 上一页 </12> 下一页

起始条目: 0 结束条目: 0

Figure 3-4

### 3. Curve display mode

The "Curve Display" button at the lower left corner of the conventional centrifugal operation interface (click to return to the operation interface of the numerical display mode) can switch the conventional centrifugal operation from the above numerical display to the curve display. Select the displayed curve by clicking the button above the curve: Speed, temperature, time, speed, and temperature can be adjusted during operation, as shown in Figure 3-5:

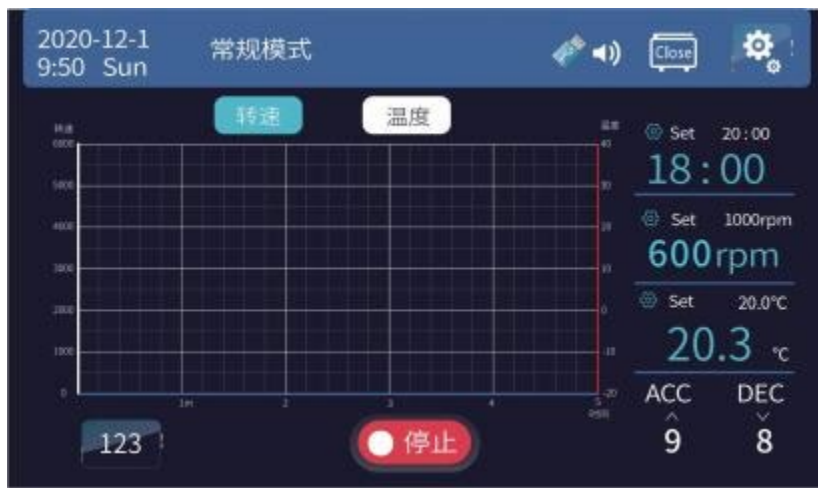

Figure 3-5. General centrifugal operation interface - Curve display

### Program centrifugal mode display is introduced

#### 4. Program setting interface

1)

Interface introduction



As shown in Figure 5-1, the program setting interface is divided into two parts:

a Program main information: The right side mainly displays, selects or edits the current program information;

b Program composition flow: The left side is the flow of the program currently displayed on the right, which can be selected by the serial number

The preceding check box selects the items to be run after startup. A maximum of 10 lines are displayed. The items are run in ascending order. Each line of the program's flow consists of four columns of information:

- Speed (or centrifugal force) : set as the target speed (or centrifugal force) of the motor running to the current process; -- Temperature: set the target temperature at which the program runs to the current process;
- Process: set the time it takes for the program to reach the target speed (or centrifugal force) from the end of the previous process to the next process;
- Time: Set the time it takes for the current process to reach the target speed (or centrifugal force) and start running.

2) Program editing and selection

3) a Choice of a program

Click the triangle drop-down key to the right of the program name, as shown in the following figure 4-1 box selection, there will be a column table of all program names, click the program name to be displayed in the list, the list is closed, and the interface displays the program just selected.

To the right of the list, you can turn the page by clicking the triangle button, as shown by the arrow.



Address: Room 1806, Block 3, Jinyun COFCO, Qianjin 2nd Road, Xixiang, Baoan District, Shenzhen City, China Website: [www.smthelp.com](http://www.smthelp.com)

Tel: +86-755-83203237;

Fax: +86-755-23240492

Figure 5-2. Select a program name from the drop-down list

b Program creation and deletion

-- New: As shown in Figure 5-2, click "+" at the bottom left of the drop-down list to enter the program editing page, as shown in Figure 4-2-2;

Program main information list on the right: Enter the name of the new program and cup number, it will automatically bring out the maximum speed and centrifugal force.

The left program consists of the flow list: Click the blank column corresponding to the parameters of each row of the 4 column headings to enter the editing page. When editing each program process for the first time, you can edit the input continuously, that is, after the input of the speed, you can automatically jump to the input of the temperature. Unless you manually click "Exit", the input box will automatically close after the input of the parameters of the "Time" column.

Address: Room 1806, Block 3, Jinyun COFCO, Qianjin 2nd Road, Xixiang, Baoan District,  
Shenzhen City, China Website: [www.smthelp.com](http://www.smthelp.com)

Tel: +86-755-83203237;

Fax: +86-755-23240492

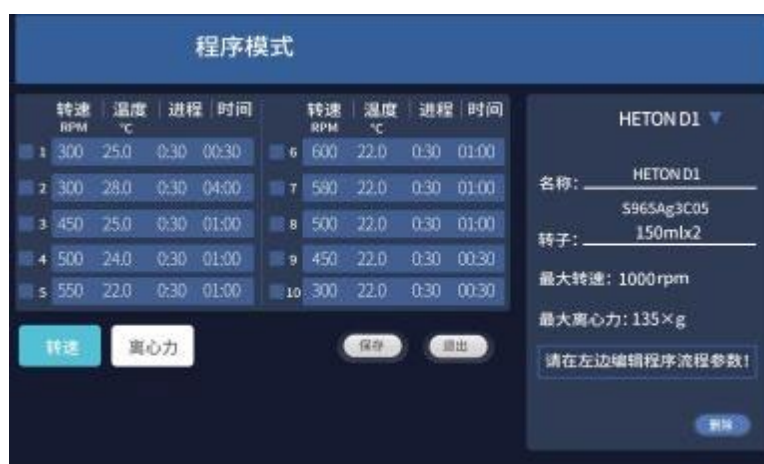

Figure 5-3. Program new page

After all the information is edited, click the Save button to confirm that the previously edited data is saved, and the editing mode will automatically exit. Otherwise, the "Exit" button will exit directly without saving the modified data.

-- Delete: As shown in Figure 5-3, the "Delete" button at the lower right corner of the program main information list can directly delete the program, and then "exit" key to exit the editing page.

### c Modification of program

After selecting the modified program in the program mode setting interface, click "Edit program" under the program main information list to enter the program editing page to modify the program selected in this section. The modification method is the same as that of creating the program above.

### 3) Other information

a Maximum of 100 programs can be created;

b Each program can be allowed to allow a maximum of 10 program flow, a minimum of 1;

c Different rotor types correspond to specific maximum speed and maximum centrifugal force, up to 9 rotor types to choose from; See Factory Settings for rotor parameter editing.

### 5、Program run interface

After selecting and editing the program and program flow information, click "Start" to start the operation, as shown below:

Address: Room 1806, Block 3, Jinyun COFCO, Qianjin 2nd Road, Xixiang, Baoan District, Shenzhen City, China Website: www.smthelp.com

Tel: +86-755-83203237;

Fax: +86-755-23240492



Program run interface

Address: Room 1806, Block 3, Jinyun COFCO, Qianjin 2nd Road, Xixiang, Baoan District,  
Shenzhen City, China    Website: [www.smthelp.com](http://www.smthelp.com)

Tel: +86-755-83203237;

Fax: +86-755-23240492



Figure 5-2. View the program flow

Stop and fault alarm: same as conventional centrifugal mode

### 1. Parameter editing

Click the configurable parameter area, a numeric keypad will appear, indicating the current configurable parameter range, input the data within the range, press "input", automatically exit the numeric keypad, input data is the set parameter value, the parameter value is automatically saved, otherwise directly press "exit", the parameter value is not saved; If the input data exceeds the set range, the input data is invalid and the set parameter values remain unchanged, as shown below.



Numeric keypad input pop-up window

Full letter keyboard input popup window

Address: Room 1806, Block 3, Jinyun COFCO, Qianjin 2nd Road, Xixiang, Baoan District, Shenzhen City, China Website: [www.smthelp.com](http://www.smthelp.com)

Tel: +86-755-83203237;

Fax: +86-755-23240492

If you enter a parameter that requires letter input, for example, a program name, a full-letter keyboard is displayed. OK indicates to confirm the input, <- indicates to delete, and ESC indicates to exit the keyboard. Figure 5-2.

Address: Room 1806, Block 3, Jinyun COFCO, Qianjin 2nd Road, Xixiang, Baoan District,  
Shenzhen City, China Website: [www.smthelp.com](http://www.smthelp.com)

Tel: +86-755-83203237;

Fax: +86-755-23240492



## 5.2 Power on

Connect one end of the supplied power cord to the power socket on the back wall of the machine, and the other end to the mains power supply. The mains power supply should use an independent socket. The power supply range used by this machine is AC230V 50HZ/60HZ. After the connection is complete, turn on the power switch located on the right side of the back of the machine. The buzzer will make a short sound, the touch display on the control panel will light up, and after the self-test of the machine is completed, the main interface will be entered, and the next operation can now be carried out.

## 5.3 Open the door

Press the door opening key on the control panel, the door cover will automatically open and spring up to a certain height under the action of the damping gas spring, and the inner chamber will be presented to the user.

Note: When opening the door, the door cover will automatically spring up to a certain height, at this time should prevent the head or other items above the door cover, so as to avoid danger!

If a fault occurs, the door cover cannot be opened automatically, and if the items in the chamber must be removed at this time, the method of manually opening the door can be used, specifically see "Troubleshooting".

## 5.4 Close the door

Push the door cover down until the front side hook of the door cover slides over the lock dowel and a click is heard. The bottom of the hook will contact the travel switch and the door is locked.



**When closing the door, the door cover should be properly pressed, do not force too hard, so as not to damage the electric lock hook!**

Address: Room 1806, Block 3, Jinyun COFCO, Qianjin 2nd Road, Xixiang, Baoan District, Shenzhen City, China Website: [www.smothelp.com](http://www.smothelp.com)

Tel: +86-755-83203237;

Fax: +86-755-23240492

## 5.5 Install the carriage mechanism assembly

The turnstile used must be the product confirmed and designated by the company, otherwise it will cause failure. The specifications and models of all kinds of turnstile confirmed by the company are attached to this description book. The company recommends users to use the various types of transfer specifications specified in this manual (see "Table 1: Transfer Types and Technical parameters").



**The use of optional parts such as improper cup types and cup body specifications can lead to poor centrifugation and even damage to the mixer! (Cup body customization is acceptable)**

**The steps to install the rotating frame are as follows (as shown in the figure below)**

- Turn on the power switch until the self-test is complete;
- Press the door opening button, automatically open the blender door cover, and confirm that the chamber is clean, clean and free of foreign bodies;

Address: Room 1806, Block 3, Jinyun COFCO, Qianjin 2nd Road, Xixiang, Baoan District,  
Shenzhen City, China      Website: [www.smthelp.com](http://www.smthelp.com)

Tel: +86-755-83203237;

Fax: +86-755-23240492

- Clean the surface of the motor spindle;
- Prepare the rack mechanism you want to use as shown in Figure 5. Hold the rotating frame with both hands, align the center hole of the rotating frame with the motor spindle, put it down vertically, place it at the bottom of the cone, release your hands, and then press down the rotating frame with your hands.

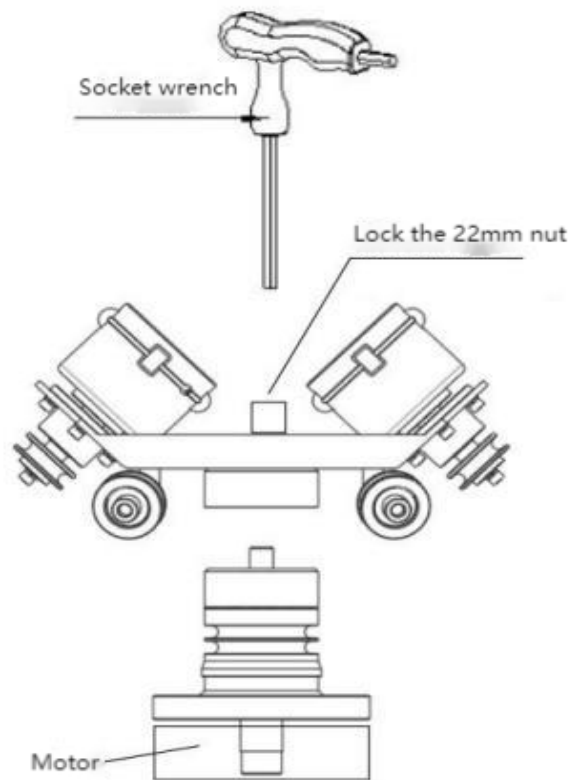

- Use the tool (special 22mm socket wrench) to disassemble the rotating frame and tighten the locking nut in a clockwise direction;

**Figure 5: Mounting the rotating frame**

Address: Room 1806, Block 3, Jinyun COFCO, Qianjin 2nd Road, Xixiang, Baoan District, Shenzhen City, China Website: [www.smthelp.com](http://www.smthelp.com)

Tel: +86-755-83203237;

Fax: +86-755-23240492



**After installing the rotating frame mechanism, before each use or after a period of time, check whether the installation position of the rotating frame has changed, and if necessary, tighten the locking sleeve again to ensure that the rotating frame is firmly installed.**

Address: Room 1806, Block 3, Jinyun COFCO, Qianjin 2nd Road, Xixiang, Baoan District,  
Shenzhen City, China      Website: [www.smthelp.com](http://www.smthelp.com)

Tel: +86-755-83203237;

Fax: +86-755-23240492

## 5.6 The calculation of the load of the rotating frame

- Calculation of maximum load

S1000D desktop automatic centrifugal mixer at low speed, there is a huge centrifugal force; When each frame is designed, it is required to have sufficient mechanical strength - the "safety factor" - when working at the maximum rated speed; However, this "safety factor" regulation requires that the rotating load shall not exceed its maximum rated load.

If the sum exceeds the maximum rated load of the rotor when you place the sample in the container together while mixing the sample, you must reduce the weight of the sample or calculate the allowable speed of the rotor (NPERM) to ensure that the rotor load does not exceed its maximum rated load.

The allowable operating speed (NPERM) of the rotor is calculated as follows:

$$NPERM = N_{max} \times (\text{maximum permissible load} \div \text{actual load}) \times 0.5$$

$N_{max}$ : Maximum rated speed;



**Do not overload the use of the rack, otherwise it will cause safety accidents, damage and destruction of debris will damage the centrifugal mixer!**

## 5.7 Filling of samples in centrifugal mixing vessels

When the centrifugal mixer is running, the better the balance performance, the mixing area of the stirring product will not interfere with each other due to vibration, so the mixing effect is better. Therefore, when the sample is filled into the mixing container cup, it can achieve a better balance effect during operation. All samples must be placed in appropriate containers.

Carefully check whether the centrifugal mixing container used (solder paste cup glue cup, etc.) conforms to its maximum allowable rated acceleration (centrifugal force); In the case of meeting the requirements, please reduce the operating speed.



**Please pay attention to the service life of the centrifugal mixing container used, especially when**

Address: 1806, Block 3, Jinyun COFCO, Qianjin 2nd Road, Xixiang, Baoan District, Shenzhen City, China Website: [www.smthelp.com](http://www.smthelp.com)

Tel: +86-755-83203237;

Fax: +86-755-23240492

**operating at the highest allowable load and speed, the centrifugal mixing container (plastic, metal container) should be checked for damage, if any, it should be replaced in time.**

## **5.8 Safe use of rotating frame mechanism**

**5.8.1** Samples and test tubes should be loaded and placed accurately and symmetrically before operation.

**5.8.2** When installing the horizontal cup holder, please pay attention to whether the pin of the pipe frame is reliably inserted into the slot holes on both sides of the pipe frame, and then turn the rotating frame by hand to see whether it is flexible.

**5.8.3** Do not run for a long time in the 1000r/min critical speed area, otherwise it will cause large vibration of the machine and affect the service life.



**When the rotor lock sleeve is not tightened on the rotating shaft, do not start!**

**5.8.4** If you need to run the centrifugal mixer repeatedly, you must check whether the lock sleeve is loose after several times of use, if it is loose, it must be tightened and then turned on.

**5.8.5** The centrifugal mixing cup body can not load samples at the same time, but must be symmetrically loaded samples (allow weight error  $\leq 50g$ ), asymmetrically loaded samples must not be allowed to start operation.

(Temporary 200g maximum unbalance allowed, but not recommended)

## 5.9 Example for parameter setting operations

**5.9.1** If the machine is configured with a cup of 150ml $\times$ 2, the specific operation is as follows: Power on  $\rightarrow$  Turn on the power switch on the back right side of the machine, then the main control interface will be displayed on the color screen. For example, you need to set the following parameters:

Seasonal setting	Cup temperature Settings	Double cup temperature setting	Optimum speed r/min.	Time/min.	remark
Summer	0-10	0-10	600	6	Just adjust the time Settings
Winter	23-25	25-28	500	10-12	Temperature. Time setting adjustment
Spring & autumn	22-23	25-26	500-600	6-10	Temperature. Time Settings fine-tune

Vacuum tank: optional vacuum pump and pressure gauge handle

Example: Conventional mode: the above single cup/double cup solder paste Settings: temperature speed time three main Settings

Set a reference value, users in different climate areas can set adjustment according to the effect of stirring; For example, add or subtract fine-tuning based on reference temperature and time setting; The purpose of setting 0-10 degrees in summer is to stop

Address: Room 1806, Block 3, Jinyun COFCO, Qianjin 2nd Road, Xixiang, Baoan District, Shenzhen City, China Website: [www.smthelp.com](http://www.smthelp.com)

Tel: +86-755-83203237;

Fax: +86-755-23240492

the temperature control system from working. The ambient temperature in summer fully meets the requirements of the return temperature environment, and you only need to set the speed and time Settings.

(High-end processes can be set using program mode - see program mode setting introduction for details)

**5.9.3 Speed setting:** On the control screen, press → Parameter adjustment to set the speed to 300-1000rpm.

**5.9.4 Time setting:** Control panel

**5.9.5 Speed setting (starting the machine to make the rotating frame run to the set speed and stopping the machine running acceleration and deceleration Settings, the value is 0 ~ 9, the larger the value, the shorter the time used) :**

**5.10.1 Relative centrifugal force setting:**

- Before setting parameters with the control panel, the rotating frame mechanism must be correctly installed on the rotating shaft.
- If you find an error in the parameter setting process, you can reset the parameters.

**5.10.7 The calculation of centrifugal force**

The relative centrifugal force is generally thousands of times the Earth's gravity (g) and is a unit used to measure the efficiency of various instruments in separating or settling materials. The calculation of centrifugal force is related to the centrifugal speed and centrifugal radius, which are calculated according to the following equation:

$$RCF= 11.18 \times (n/1000)^2 \times r$$

r: the centrifugal radius in centimeters;

n: Centrifugal speed, unit rpm (revolutions per minute)

Note: "The maximum centrifugal force value is related to the maximum centrifugal radius";

The "centrifugal force value" set should take into account the radius of the rotor and the shape of the centrifugal vessel.

Address: Room 1806, Block 3, Jinyun COFCO, Qianjin 2nd Road, Xixiang, Baoan District, Shenzhen City, China Website: [www.smthelp.com](http://www.smthelp.com)

Tel: +86-755-83203237;

Fax: +86-755-23240492



## 6 Maintenance items

### 6.1 Cleaning and purification

If hazardous substances spill or enter the equipment, the user is responsible for proper decontamination.



**The user shall clean and purify the product in accordance with the methods described in this manual**

**To ensure that the equipment is not damaged; The use of improper cleaning agents and improper disinfection procedures may cause damage to the centrifugal mixer and internal components;**

#### 6.1.1 Implementation of cleaning and purification



**Before cleaning the centrifugal mixer, please turn off the power switch and unplug the power cord!**

Regular (or according to the use) cleaning and maintenance of the operation content mainly on the mixer shell, inner cavity, rotary and the use of mixing containers; This is to prevent pollutants from being left on top, causing corrosion and environmental pollution to the parts used.

Address: Room 1806, Block 3, Jinyun COFCO, Qianjin 2nd Road, Xixiang, Baoan District, Shenzhen City, China Website: [www.smthelp.com](http://www.smthelp.com)

Tel: +86-755-83203237;

Fax: +86-755-23240492



**Do not use organic solvents, because it can decompose the motor bearing lubrication grease; During the cleaning process, the liquid, especially the organic solvent, should not come into contact with the motor spindle and bearing inner ball!**

## **6.1.2 Maintain**

**6.1.2.1** Do not use pointed objects to collide with the rotor, to prevent bumping during handling and disassembly, to prevent cracks caused by scratches or trauma in use.

**6.1.2.2** Regularly check the rotating frame components (especially the bottom of the tube hole) for corrosion spots, grooves, and small cracks. If any of the above conditions are found, please stop using the rotating frame and contact the company.



**When disassembling the cup turnstile mechanism (referred to as the turnstile), first remove the synchronous belt from the wheel groove, grab the turnstile with both hands, lift it vertically up, do not Shake from side to side!**

**6.1.2.3** Under normal circumstances, the wall of the cup cavity is cleaned once a week, if the mixing cup remains or other corrosive samples, please clean immediately after use. If the sample is found to spill, dip or drop on the cup during use, it should be immediately drained and locally cleaned.

**6.1.2.4** When cleaning the turnstile, wet it with a neutral detergent sponge or cotton cloth, and then wash off the cleaning agent with distilled water. Do not sprinkle or spray the rotor with water, as the liquid may be retained and cause corrosion. Allow to dry upside down after cleaning.

**6.1.2.5** Use rags or tweezers to remove pieces of stolen goods from the centrifugal chamber.

**6.1.2.6** The connecting parts of the motor shaft and shaft hole of the rotating frame should be coated with grease.

**6.1.2.7** Maintenance of the motor spindle steps:

- Turn on the power switch until the self-test is complete;
- Press the door key to open the centrifugal mixer door cover;
- Loosen the locking sleeve and take out the rotating frame mechanism with the special tool that comes with it, and clean the locking sleeve. Note: the clockwise direction is to tighten the locking sleeve, and the counterclockwise direction is to loosen the locking sleeve;

Address: Room 1806, Block 3, Jinyun COFCO, Qianjin 2nd Road, Xixiang, Baoan District, Shenzhen City, China Website: [www.smthelp.com](http://www.smthelp.com)

Tel: +86-755-83203237;

Fax: +86-755-23240492

- Clean the cone of the motor spindle, do not leave stolen goods, can add the appropriate amount of lubricating oil or smear with lubricating paper;

**6.1.2.8** When disassembling the machine, the power supply must be cut off first, and the power cord connected to the back wall of the machine must be unplugged, and the live operation is not allowed to prevent the relevant personnel from electric shock or damage to the machine. Note: This operation can only be carried out by our specially trained maintenance personnel!

**6.1.2.9** This machine can only use parts provided by Southern Machinery.

**6.1.2.10** When the centrifugal mixer is not in use, the power supply should be cut off

**6.1.2.11** Transportation and storage

This machine is a precision instrument. Machinery and equipment, in the process of transportation and storage, please pay attention to moisture, shock, do not put sideways or upside down.

Address: Room 1806, Block 3, Jinyun COFCO, Qianjin 2nd Road, Xixiang, Baoan District,  
Shenzhen City, China Website: [www.smthelp.com](http://www.smthelp.com)

Tel: +86-755-83203237;

Fax: +86-755-23240492

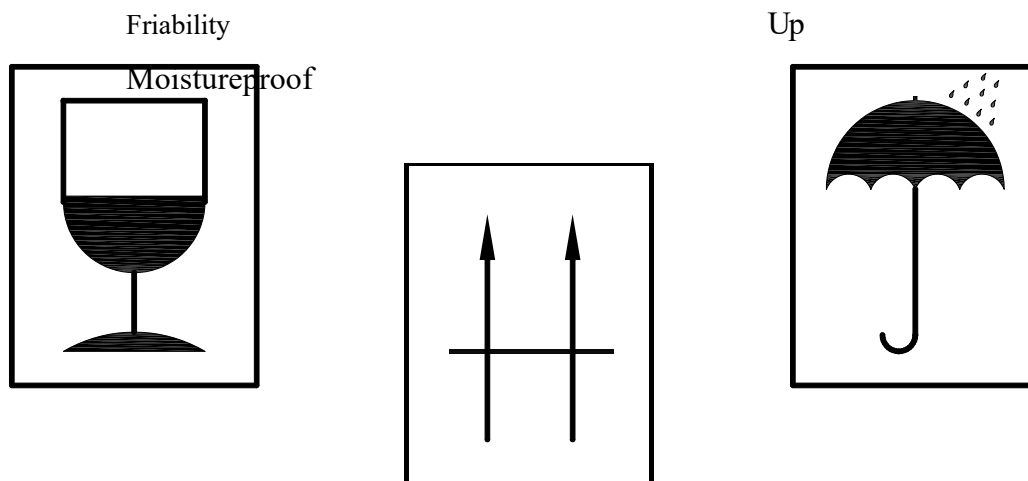

**Figure 7: Transport and storage precautions**

## 6.2 The maintenance responsible by Southern Machinery

The S1000D desktop automatic centrifugal mixer produced by Southern Machinery, the user must be regularly repaired and maintained by the maintenance personnel for the whole machine more than once a year, the main contents of maintenance are:

- Check some functions of electrical appliances (such as whether the temperature display is normal, and the temperature sensor is on the aluminum pressure plate of the upper cover);
- Solid stability inspection of the machine place;
- Electromagnetic door lock mechanism and other safety circuit inspection;
- Check the locking device of the rotating frame and the motor spindle (drive shaft);
- Maintenance personnel clean and check the performance of the rotating frame mechanism.

Southern machinery to provide on-site maintenance needs to be charged, the specific amount of charges by both parties reflected in the sales contract.

Address: Room 1806, Block 3, Jinyun COFCO, Qianjin 2nd Road, Xixiang, Baoan District, Shenzhen City, China Website: [www.smothelp.com](http://www.smothelp.com)

Tel: +86-755-83203237;

Fax: +86-755-23240492

In the process of maintenance, parts that need to be replaced are found to be free during the warranty period, otherwise they need to be charged.

### **6.3 Warranty (repair) basis**

Warranty period (warranty period) from the user received the product, during the warranty period (warranty period), if the product fails, the maintenance personnel of Southern Machinery is responsible for free on-site repair, if the need to replace the parts is due to its own quality, not caused by human improper use, you can be replaced free of charge. Otherwise you have to pay. Enclosures are not covered by warranty!

Warranty (repair) basis

- The user shall operate according to the requirements of this instruction manual;
- Installation, commissioning, moving position, adding accessories, maintenance and other work, is the Southern Machinery designated or specialized personnel responsible;
- The usual maintenance is performed regularly according to the method specified in this instruction manual;
- If the above requirements are not met, that is, the damage caused by improper use of the user, Southern Machinery Company is responsible for repair

Yes, but not for free.

Pay attention to the vulnerable parts: touch screen, extended USB seat, emergency door lock; The drive belt is a worn part.

Southern Machinery guarantees that within 12 months after the sale of the machine, any problems related to the quality of the machine will be covered by this unit. Out-of-warranty repairs will be made for a fee.

(Except for damage caused by improper use of the user) (Please consult Southern Machinery or agents for extended warranty)

Address: Room 1806, Block 3, Jinyun COFCO, Qianjin 2nd Road, Xixiang, Baoan District, Shenzhen City, China      Website: [www.smothelp.com](http://www.smothelp.com)

Tel: +86-755-83203237;

Fax: +86-755-23240492

## 7 Fault handling

### 7.1 Emergency door cover

In normal use, due to accidental power failure or the failure of the door opening operation, you can not use the function of the automatic door opening, but you must remove the items in the centrifugal chamber, in this case, you can use the manual door opening method of the centrifugal mixer to open the door cover and remove the mixing sample. Note: This method is only allowed to use in emergency situations, do not use casually!



**When the power is cut off, the cup stops running without brake function, it takes a long time to completely stop running, please wait patiently!**

Emergency door opening steps are as follows:

- 7.1.1 Make sure the cup has stopped completely;
- 7.1.2 Turn off the power switch;
- 7.1.3 Slowly pull the emergency door lock rope horizontally to the right, the door cover will be opened, and then you can remove the mixing sample from the centrifugal mixer;

### 7.2 Fault alarm information

The following table lists the alarm information issued by the machine and the related fault causes and handling methods, you can eliminate according to the prompt; If the user fails to rectify the fault after an attempt or if the alarm is not included in the

Address: Room 1806, Block 3, Jinyun COFCO, Qianjin 2nd Road, Xixiang, Baoan District,  
Shenzhen City, China Website: [www.smthelp.com](http://www.smthelp.com)

Tel: +86-755-83203237;

Fax: +86-755-23240492

following list, the user should immediately contact the maintenance personnel of Southern Machinery.



**When an exception occurs, turn off the power supply and start the power supply after the fault is rectified.。**

Address: Room 1806, Block 3, Jinyun COFCO, Qianjin 2nd Road, Xixiang, Baoan District,  
Shenzhen City, China      Website: [www.smthelp.com](http://www.smthelp.com)

Tel: +86-755-83203237;

Fax: +86-755-23240492



Parameter name	Radius	Parameter meaning	Default value
Door cover protection	on-off	Open: start the door cover detection, open the cover running alarm; Off: start without door cover detection, open cover operation without alarm	开
Alarm state	open-close	This only the door cover protection open state is effective open: the door cover open indicates that the door cover is closed; Closed: the short connection of the door cover interface means the door cover is closed;	开路
Time unit	HH : MM MM:SS	HH:MM Time setting unit: hour and minute. MM: SS Time setting unit is minute second timing;	MM:SS
Screen saver	0-60 minutes	OM: indicates that the command is disabled. 1-60 m: Enable. After setting the value, the screen saver is displayed when the main screen does not operate. Tap the screen to wake up	2M
Driver type	BLDC FOC VDF	TJ-BLDC: Brushless BOLDC communication TJ-FOC: brushless TJ-FOC communication TJ-VDF: frequency conversion communication	FOC
Starting torque	10~200	The higher the value, the faster the startup speed	80
Driver version		Driver version number	

Address: Room 1806, Block 3, Jinyun COFCO, Qianjin 2nd Road, Xixiang, Baoan District, Shenzhen City, China Website: [www.smthelp.com](http://www.smthelp.com)

Tel: +86-755-83203237;

Fax: +86-755-23240492

Rotational speed	300~1000	Current rotation range of the rotating frame mechanism	1000
Centrifugal force	12~135	Current maximum relative centrifugal force of the rotating frame mechanism	135
Lift time	2~1500	9 speed lift time	15
Interval time	2~150	The interval between lifting and lowering the speed of adjacent gears	5
Password management		Default factory setup password and program upgrade password	
Heating setting		Temperature control parameter Settings	
Display magnification	0~4	Set the relationship between the displayed value and the actual value: 0: The set value is displayed directly; 1: Display the actual measured value; 2: The display error is 1/2 of the actual error; 3: The display error is 1/4 of the actual error;	1
Upper deviation	1~4	Unit ° C, the allowable positive error range of temperature control	1
Lower deviation	1~4	Unit ° C, the allowable negative error range of temperature control	1
Heating time	0~100	Unit S, heating limit time: 0 indicates off	0
Temperature calibration	-5~5	Unit ° C, calibration temperature measurement error	
To lead into		Import system and model setting parameters	
Derive		Export system and model Settings	

Address: Room 1806, Block 3, Jinyun COFCO, Qianjin 2nd Road, Xixiang, Baoan District, Shenzhen City, China Website: [www.smthelp.com](http://www.smthelp.com)

Tel: +86-755-83203237;

Fax: +86-755-23240492

Address: Room 1806, Block 3, Jinyun COFCO, Qianjin 2nd Road,Xixiang, Baoan District,  
Shenzhen City, China Website: [www.smthelp.com](http://www.smthelp.com)

Tel: +86-755-83203237;

Fax:+86-755-23240492

**Table 3: Fault alarm information and handling measures**

Fault type	Cause, fault description	Treatment countermeasure
Unbalance	The unbalanced protection input switch is closed	<ul style="list-style-type: none"> <li>● The tilt force of the instrument is inconsistent, and the water level of the instrument is adjusted to make its force consistent</li> <li>● Motor spindle is bent, contact Southern Machinery to replace the motor</li> </ul>
Overspeed	Speed measurement interference or too fast rise, continuous 2S of measurement speed higher than the maximum set speed +500rpm	<ul style="list-style-type: none"> <li>● Check the speed measurement line and reduce the speed increase gear</li> <li>● Speed sensor failure, contact Southern Machinery</li> </ul>
Door cover protection	The door cover is not closed, or the electronic lock of the door cover switch is faulty	<ul style="list-style-type: none"> <li>● Close the door again</li> <li>● Door cover switch and electric lock are damaged, contact Southern Machinery to replace</li> </ul>
Rate-free	No speed signal is transmitted	<ul style="list-style-type: none"> <li>● Please check the external power supply voltage, manually turn the frame to check whether it is smooth, and then restart</li> </ul>
Communication error	The communication between the main control board and the	<ul style="list-style-type: none"> <li>● Check whether the wiring between the display board and the drive board is well connected.</li> </ul>

Address: Room 1806, Block 3, Jinyun COFCO, Qianjin 2nd Road, Xixiang, Baoan District, Shenzhen City, China Website: [www.smthelp.com](http://www.smthelp.com)

Tel: +86-755-83203237;

Fax: +86-755-23240492

	driver failed	
Temperature error	The temperature sensor is in poor contact or damaged	Check whether the temperature sensor is properly connected or contact the Southern Machinery to replace the temperature sensor



**Special note:**

**The minimum set speed is 300 rpm. The program number cannot be reset when the system is running.**

**Table 4: Fault symptoms, causes and troubleshooting methods**

Fault phenomenon	Fault cause and troubleshooting method
The machine does not display or the machine suddenly does not display	<ol style="list-style-type: none"> <li>1. Check whether the power socket and connection are good and whether the power socket has power.</li> <li>2, whether the power switch contact is not good.</li> <li>3, check the fuse, if bad, please replace the spare fuse.</li> <li>4, if can not be ruled out, please contact Southern Machinery maintenance personnel.</li> </ol>
The machine stopped suddenly in the middle of operation	<ol style="list-style-type: none"> <li>1. Exceed the maximum rated speed of the rotating frame mechanism.</li> <li>2, once the rotating speed exceeds the rated speed of the mechanism 450r/min or more, the overspeed alarm will be used. At this time, the speed must be reset after stopping.</li> <li>3. Exceed the set speed of the rotating frame.</li> <li>4. When the motor overheats, the power supply is cut off inside the machine, and the machine stops running at this time.</li> <li>5, if the keyboard panel is not displayed, please check the power supply system of the machine.</li> <li>6, the voltage may be too low, check whether the power supply voltage meets the requirements.</li> </ol>
The door won't open	<ol style="list-style-type: none"> <li>1, the rotating frame mechanism is not completed to stop rotating, the door should not be opened.</li> <li>2, check the door lock components.</li> <li>3. Check the electrical wiring of the door lock.</li> <li>4, using manual method to open the door.</li> <li>5, if can not be ruled out, please contact Southern Machinery maintenance personnel.</li> </ol>

Large machine vibration	<ol style="list-style-type: none"> <li>1, the rotating frame is too critical speed, some vibration of the machine is normal.</li> <li>2. Check whether the rotating frame is locked.</li> <li>3, check the symmetry of the transfer load, check the level of the machine.</li> <li>4. Check whether the transfer frame is installed properly.</li> <li>5, check the drive shaft, hand rotation, if not smooth rotation, there may be a problem with the drive shaft or motor, if you can not rule out, please contact the maintenance personnel of Southern Machinery.</li> </ol>
After turning on the power switch, Touch panel indication The light doesn't work.	<ol style="list-style-type: none"> <li>1. If the power supply is not connected, check the power distribution.</li> <li>2, PCB board and power socket fuse is broken, please professionals replace the fuse.</li> <li>3, if can not be ruled out, please contact Southern Machinery maintenance personnel.</li> </ol>
The operation panel is abnormal	<ol style="list-style-type: none"> <li>1, may be caused by grid interference, please shut down, wait for one minute after the shutdown and then turn on, the display can be normal</li> </ol>
The motor does not turn after pressing the start button	<ol style="list-style-type: none"> <li>1, the electrical control circuit is bad, replace the electrical control board.</li> </ol>
The machine smells of burnt smoke	<ol style="list-style-type: none"> <li>1. Cut off the power supply.</li> <li>2. Whether the motor is burned.</li> <li>3. Whether the electrical components are burned.</li> <li>4, rotate the drive shaft by hand, if not smooth transmission, you can ask the professional personnel of the manufacturing unit to solve.</li> </ol>
Exceed the preceding fault information	<ol style="list-style-type: none"> <li>1, by the manufacturing unit professional personnel to solve.</li> </ol>

Address: Room 1806, Block 3, Jinyun COFCO, Qianjin 2nd Road,Xixiang, Baoan District, Shenzhen City, China Website: [www.smthelp.com](http://www.smthelp.com)

Tel: +86-755-83203237;

Fax:+86-755-23240492

### 7.3 Machine running record

In order to ensure the normal operation of the machine, extend the service life of the machine; In order to accumulate data on machine operation and diagnose the causes of faults or accidents, it is important to carefully record each operation (one copy per machine). The recommended operating record is as follows:

Trial date	Sample name	Weight per cup (including sample)	Mixing material number	RP M	Time minute	Machine Working condition	operator
Year month day		500g	SN63PB37	600	6	normal	Lucy
	Epoxy	ml	Ag				

Address: Room 1806, Block 3, Jinyun COFCO, Qianjin 2nd Road,Xixiang, Baoan District, Shenzhen City, China Website: www.smthelp.com

Tel: +86-755-83203237;

Fax:+86-755-23240492



Address: Room 1806, Block 3, Jinyun COFCO, Qianjin 2nd Road,Xixiang, Baoan District, Shenzhen  
City, China Website: [www.smthelp.com](http://www.smthelp.com)

Tel: +86-755-83203237;

Fax:+86-755-23240492

## 8 Technical data

Function/parameter	Technical index
Use environment	<ul style="list-style-type: none"> <li>● Indoor use</li> <li>● There is no vibration and airflow affecting the performance around, and there is no conductive dust explosive gas and corrosive gas in the surrounding air</li> <li>● Altitude: <math>\leq 2000\text{m}</math></li> <li>● Relative humidity: <math>\leq 80\%</math></li> </ul>
Operating ambient temperature	<ul style="list-style-type: none"> <li>● <math>+5^{\circ}\text{C}\sim 40^{\circ}\text{C}</math></li> </ul>
Applicable supply voltage	<ul style="list-style-type: none"> <li>● AC230V 50HZ/60HZ 10A</li> </ul>
Set time range	<ul style="list-style-type: none"> <li>● 0~99Min</li> </ul>
Maximum speed	<ul style="list-style-type: none"> <li>● 1000rpm</li> </ul>
Maximum relative centrifugal force	<ul style="list-style-type: none"> <li>● <math>135\times g</math></li> </ul>
Maximum capacity	<ul style="list-style-type: none"> <li>● 150ml</li> <li>● Custom cup (please consult Southern Machinery or agent)</li> </ul>
Rate of ascent	<ul style="list-style-type: none"> <li>● The acceleration time from zero to maximum RPM is no more than 20 seconds</li> </ul>
Rate of descent	<ul style="list-style-type: none"> <li>● Deceleration from maximum RPM to zero takes no more than 30 seconds</li> </ul>
Noise (maximum speed)	<ul style="list-style-type: none"> <li>● <math>\leq 60\text{dB(A)}</math></li> </ul>
Overall dimensions (machine)	<ul style="list-style-type: none"> <li>● 582 mm (L) *500mm (W) *417mm (H)</li> </ul>
Net weight	<ul style="list-style-type: none"> <li>● 68.00 kg</li> </ul>

Address: Room 1806, Block 3, Jinyun COFCO, Qianjin 2nd Road, Xixiang, Baoan District, Shenzhen City, China Website: [www.smthelp.com](http://www.smthelp.com)

Tel: +86-755-83203237;

Fax: +86-755-23240492

Reference standard	<ul style="list-style-type: none"><li>● GB4793.1-2007 "Safety requirements for electrical equipment used in measurement and control laboratories Part I: General safety requirements";</li><li>● GB4793.7-2001 "Safety requirements for electrical equipment for measurement and control laboratories - Special requirements for centrifuges for laboratory use";</li><li>● GB191-2000 "Packaging storage and Transportation icon";</li><li>● GB6587.6-86 "Transportation Test of Electronic Measuring Instruments";</li><li>● Enterprise standard: "Low speed centrifugal mixer".</li></ul>
-----------------------	--

Address: Room 1806, Block 3, Jinyun COFCO, Qianjin 2nd Road,Xixiang, Baoan District, Shenzhen City, China      Website: [www.smthelp.com](http://www.smthelp.com)

Tel: +86-755-83203237;

Fax:+86-755-23240492

## 9 Packing list

### Table type automatic centrifugal mixer - return temperature type

#### Packing list

Number	Name	quantity	Remark
1	Machine	1 Set	
2	Power cord	1 Root	Provided in accordance with the standards of the customer's country
3	500 grams, 250 grams counterweight	2 Set	Supply on demand
4	6mm Synchronous belt	4 Root	Includes 2 pieces of spare parts
5	3,4mm Special hex wrench	2 Set	
6	20ml Maintain anti-rust oil	1 Bottle	
7	Certificate of conformity	1 Set	
8	Operation maintenance and repair manual	1 Set	

#### Instructions for unpacking :

Address: Room 1806, Block 3, Jinyun COFCO, Qianjin 2nd Road, Xixiang, Baoan District, Shenzhen City, China Website: [www.smthelp.com](http://www.smthelp.com)

Tel: +86-755-83203237;

Fax: +86-755-23240492

Check whether the appearance of the touch screen is intact;

Check the machine body. Door cover is intact; If any exception, please report immediately.

If there is no objection to unpacking, the appearance is deemed to be unqualified without damage.



**When unpacking, please check in time. If there is any discrepancy, please contact the supplier in time**

Address: Room 1806, Block 3, Jinyun COFCO, Qianjin 2nd Road, Xixiang, Baoan District,  
Shenzhen City, China Website: [www.smothelp.com](http://www.smothelp.com)

Tel: +86-755-83203237;

Fax: +86-755-23240492